

Schematic Diagram of JumboZ-500 MANUAL STEERING

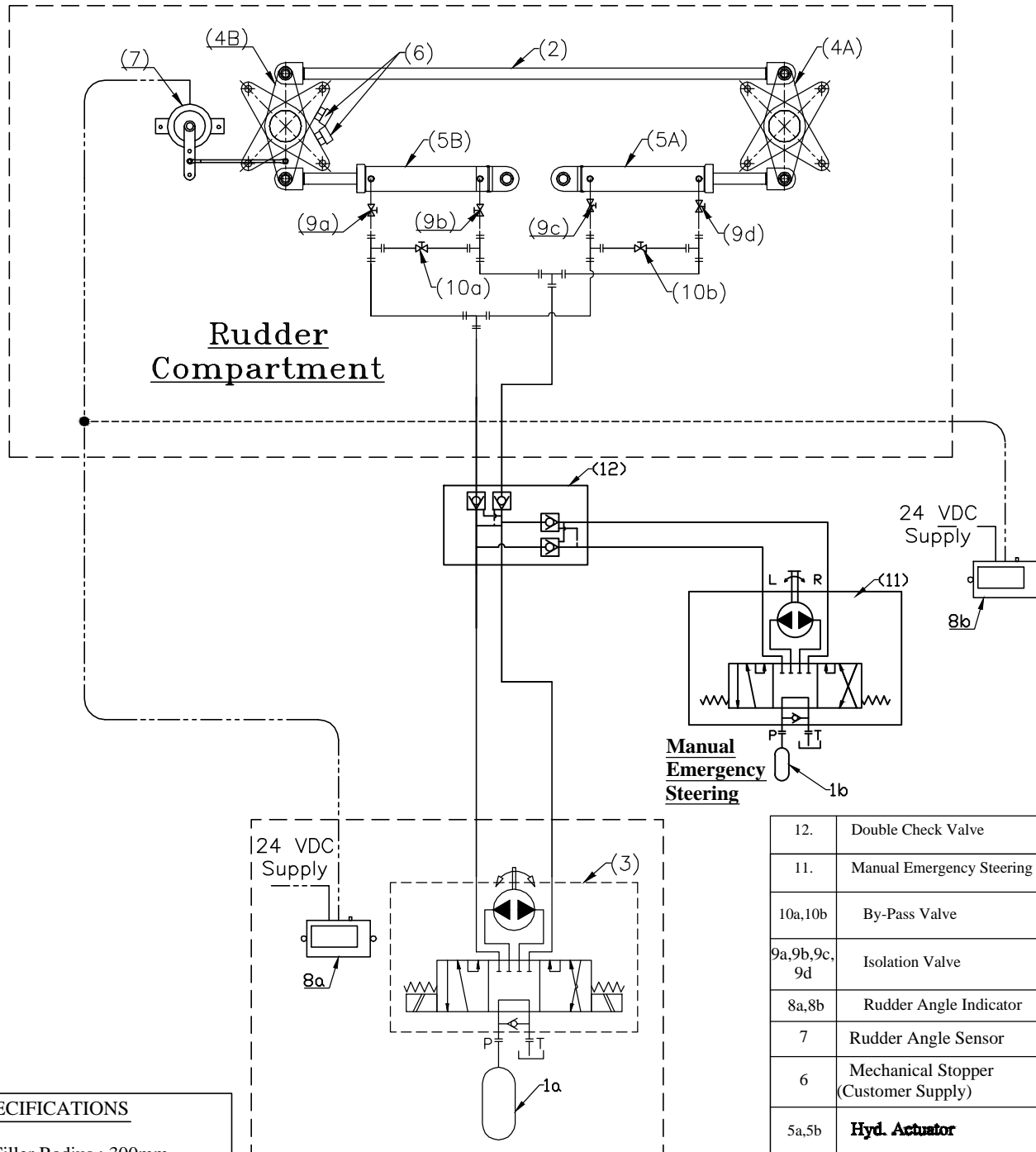

Rudder Compartment

Wheel House

SPECIFICATIONS	
1. Tiller Radius :	300mm.
2. Pump Capacity:-	Manual : 80CC/rev.
3. HYD.ACTUATOR:-	Ram : 40 mm x 2 Stroke : 440 mm.
4. PIPE :-	OD : 16mm. ID : 12MM.
5. HOSE :-	GRADE : R1 LD : 2 ^{1/2} "

12.	Double Check Valve
11.	Manual Emergency Steering
10a,10b	By-Pass Valve
9a,9b,9c, 9d	Isolation Valve
8a,8b	Rudder Angle Indicator
7	Rudder Angle Sensor
6	Mechanical Stopper (Customer Supply)
5a,5b	Hyd. Actuator
4a,4b	Tiller Arm
3.	Main Steering Unit
2.	Connection Rod (Customer Supply)
1a,1b	Oil Reservoir
Sl.no	Description

ITEM	SCALE	MATERIAL	VIEW	DRAWN	CHECKED
/	NTS	/		JK	VUK
DESIGNATION			DWG NO	DATE	QTY
Schematic Diagram of JumboZ-500M			MHS-1215	30.07.2021	/